

# Bergmann dumper on tracks

## 4010 rear tip



### Strong arguments

- ▶ high stability thanks to low center of gravity
- ▶ comfortable cab
- ▶ inside oil bath multi disc brake
- ▶ low ground pressure
- ▶ high traction

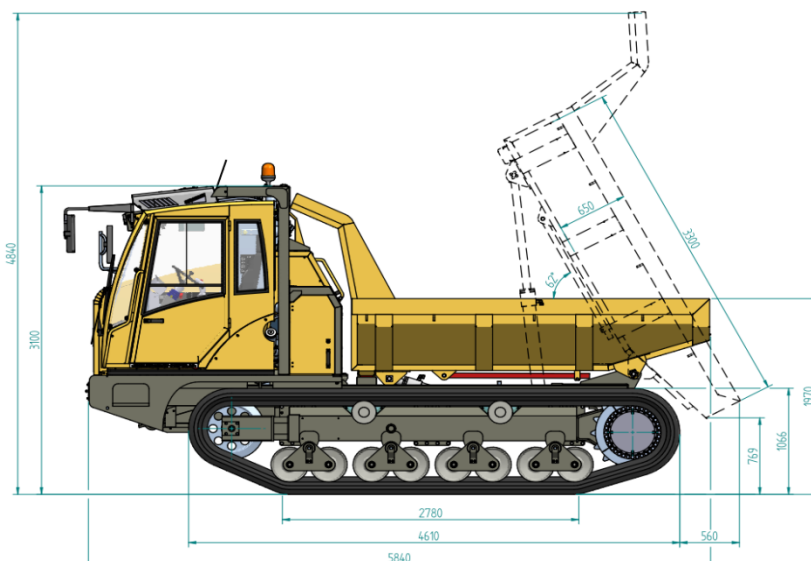



# Bergmann dumper on tracks

## 4010 rear tip

### Technical Data

<b>Weight / Capacity</b>	payload	10.000 kg
	Dead weight	14.000 kg
	Capacity struck	2.000 l
	Capacity heaped	6,5 m <sup>3</sup>
	Bucket	Hydraulic rear tip
<b>Dimensions</b>	Cabin height	3.090 mm
	Total length	5.640 mm
	Total width	2.900 mm
	Ground clearance	650 mm
<b>Transmission</b>	Hydrostatic drive with planetary transmission	
<b>Speed</b>	Working speed: 0~5 km/h	gTransport speed: 0~16 Km/h
<b>Steering</b>	Steering wheel or joystick	
<b>Brake System</b>	Inside oilbath multi disc brake	
<b>Engine</b>	Water cooled 6-cylindre Cummins Diesel engine QSB 6.7 power 180 KW/ 244 PS 2.300 U/min.	
<b>Width of Tracks</b>	750 mm	
<b>Ground Pressure</b>	0,46 kg/cm <sup>2</sup>	
<b>Engine Bonnet</b>	Fast and easy accessibility to all service points thanks to engine bonnet in 2 pieces	
<b>Quantity</b>	fuel 225 L hydraulic oil 180 L	
<b>Electric system</b>	24V electric system with mainswitch, error detection mode, fuel and hour counter, control lamps for engine oil, park brake, direction indicator, battery charge control, hydraulic filter, display for drive position	
<b>Standard equipment</b>	Comfortable cab with air suspension driver's seat, , road traffic lighting system, bucket from wear-resistant fine-grain-steel, beacon light, cigarette lighter, sun roller blind for windscreen, device for radio, loudspeaker and antenna, CE certificate Manual and spare parts list	